

Series GJ

Magnetic Drive Gear Pump

MICROPUMP®

Micropump® Series GJ pumps deliver exceptional pumping performance for any high-precision application. These compact magnetically driven gear pumps feature a cavity style design with dynamic seals to ensure leak-free performance. Series GJ pumps offer excellent chemical resistance, abrasive fluid pumping, and smooth pulseless fluid delivery. Available in standard and custom configurations, Series GJ pumps are ideal for a wide-range of fluidic applications.

Cavity Style Pumps

Cavity style pumps are excellent for wide-ranging inlet and outlet operating conditions, and allow for intermittently pumping in reverse.

Small Size

The miniature package size of the Series GJ is easily incorporated into the design of many systems.

Leak-Free

The magnetic drive and static PTFE seals keep the fluid securely inside the pump and potential contaminants out.

Smooth Pulseless Delivery

Positive displacement, precision gears provide consistent fluid delivery in continuous processes.

Chemically Resistant

Series GJ has a long-life in aggressive environments.

Easy to Service

Series GJ pumps are easy to service using a Micropump service kit and simple hand tools.



Wide Range of Options and Configurations

Micropump's designs offer the flexibility to customize products to meet your more challenging requirements including:

- ▶ Three standard gear sizes
- ▶ Multiple gear and body materials
- ▶ Optional internal bypass
- ▶ Optional high-torque magnets
- ▶ NEMA, IEC, I-Drive®, and Micropump drive mounts

Innovative Designs

Micropump uses the latest engineering tools and manufacturing equipment to produce the most innovative pumping solutions available. Products are developed using state-of-the-art CAD, Finite Element Analysis (FEA), and rapid prototyping tools to ensure the highest level of product quality and reliability.

Enhanced Efficiency

As part of the IDEX Health & Science Group, Micropump now offers fully-integrated liquid subassemblies, gas management systems, and precision components. Products include pumps, valves, manifolds, tubing, fittings, degassing/debubbling systems, air compressors, vacuum generators, and HPLC columns. Additional services are custom fluidic engineering and development, contract manufacturing, extrusion, molding, machining, and diffusion bonding.



Precision Engineered Fluidics™

Performance Summary

Flow Rate at 5,500 rpm

- ▶ 5,217 mL/min (1.38 gpm)

Displacement

- ▶ Gear Set N21 N23 N25
- ▶ mL/rev 0.316 0.64 0.91

Maximum Rated Differential Pressure

- ▶ 80 psi (5.6 bar)

Maximum Rated System Pressure

- ▶ 300 psi (21 bar)

Temperature Range

- ▶ -46–121 °C (-50–250 °F)

Viscosity Range

- ▶ 0.2–1,500 cps

Maximum Speed

- ▶ 10,000 rpm

Pump Construction

- ▶ Magnetic drive gear pump
- ▶ Cavity style
- ▶ Two helical, shafted gears
- ▶ Sleeve bushings
- ▶ PTFE bevel or o-ring seal

Wetted materials

Base material

- ▶ 316 stainless steel

Gears

- ▶ PEEK™
- ▶ PPS
- ▶ PTFE

Static seals

- ▶ PTFE

Magnets

Driven and driving

- ▶ Ferrite
- ▶ Rare earth

Product Enhancements

Internal bypass

Dimensions

A-Mount

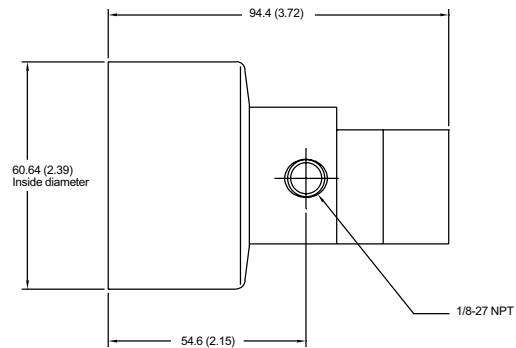

Units: mm (in.) Nominal dimensions shown.

Pump Performance

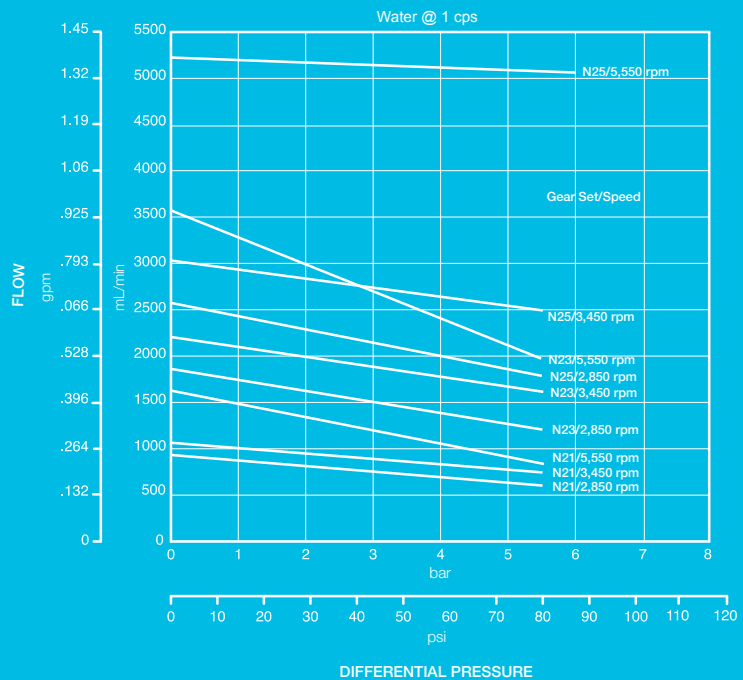

ACTUAL PERFORMANCE MAY VARY.

Specifications are subject to change without notice.

Micropump, the Micropump logo, and I-Drive are registered trademarks of Micropump, Inc. Precision Engineered Fluidics is a trademark of IDEX Health & Science. PEEK polymer is a trademark of Victrex plc. ©2008 Micropump, Inc., A Unit of IDEX Corporation.

Revised on 06/11/2008



Micropump, Inc • IDEX Health & Science Group
 1402 NE 136th Avenue • Vancouver, WA 98684
 Tel 800.671.6269 • +1.360.253.2008 • Fax +1.360.253.8294
 info.micropump@idexcorp.com • www.idex-hs.com